

Front Axo View



Rear Axo View



Top View

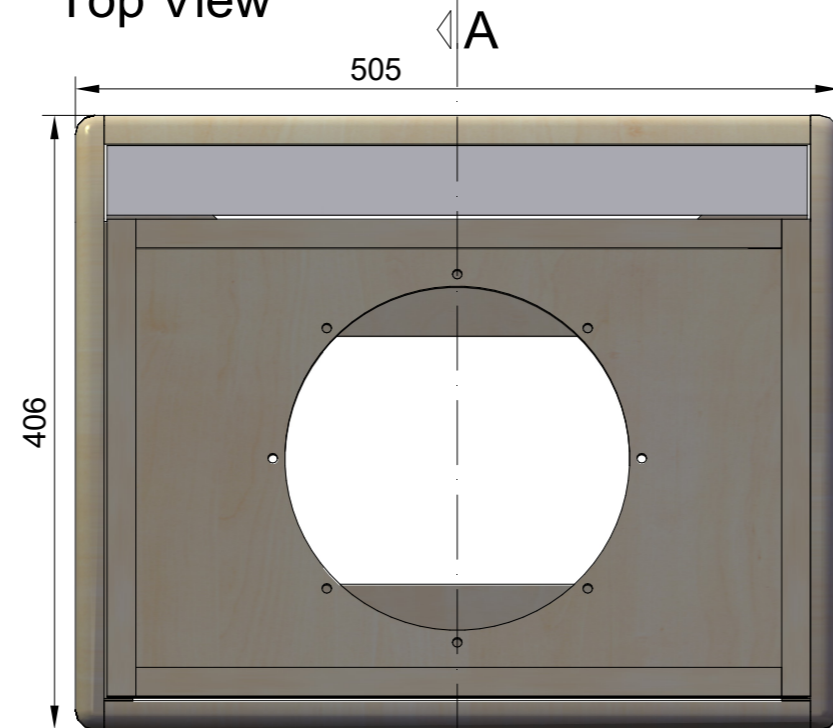

Front View

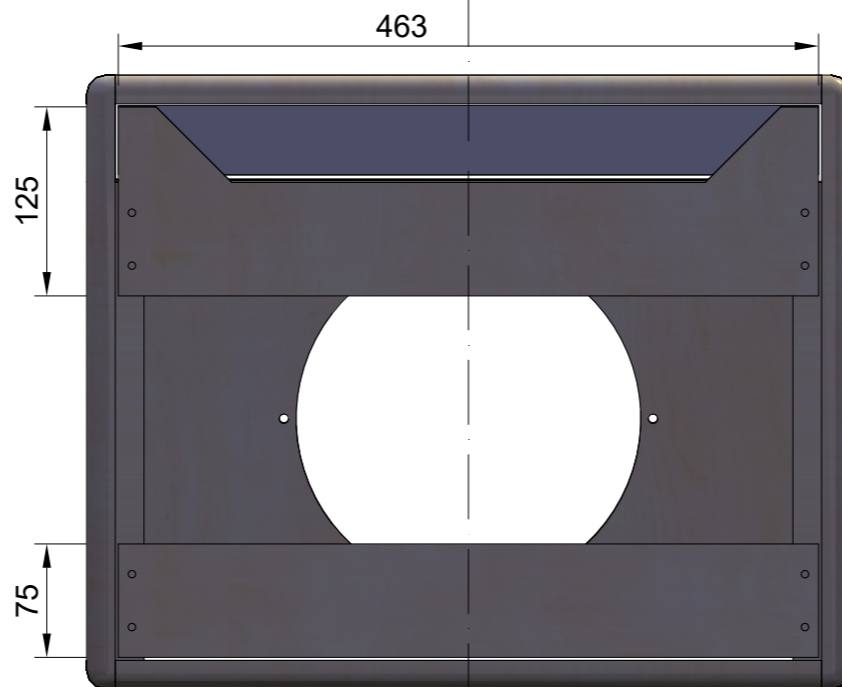

Rear View

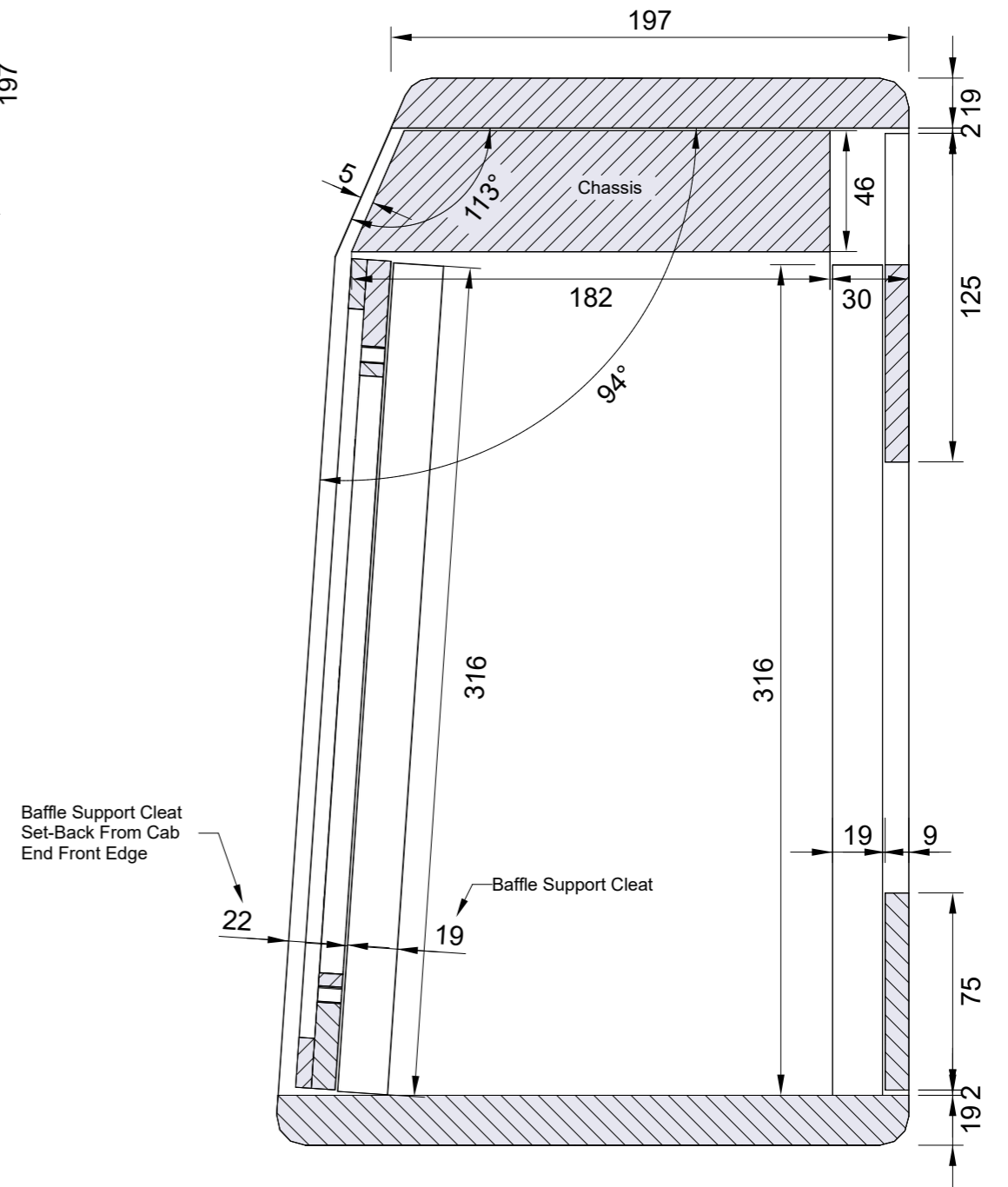

SECTION A-A

(Scale: 1:2.5@A3)

Notes:

- Drawings not to be reproduced without consent
- Check material thickness. Screw location and finger join depth will have to be adjusted to suit.
- Allowance have been made for standard vinyl covering and approx 2mm thick grille cloth.
- Dimensions may need to be altered for other materials or timber finishing.
- It's suggested that all screws be fitted with suitable T-nuts or threaded inserts for longevity.
- Hole diameter may vary with hardware choice.
- Trial and error may be required with some hardware.
- Speaker cutout and mounting holes may vary with manufacturers. measure actual unit before drilling.



Project	BGG Cabinet Plans				
Title	PR Style Cabinet (10" Driver)				
Project No.	N/A	Sheet No:	1/2	Issue	A
Drawn By	BW	Scale	1: 5@A3 (UNO)	Date	21/01/24

Lower Back Panel (9mm ply):

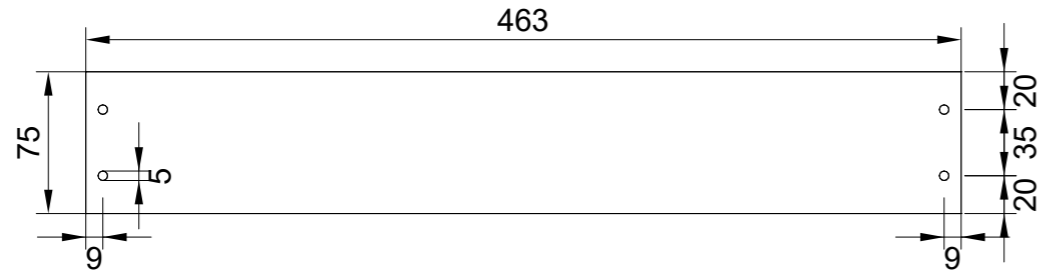

Upper Back Panel (9mm ply):

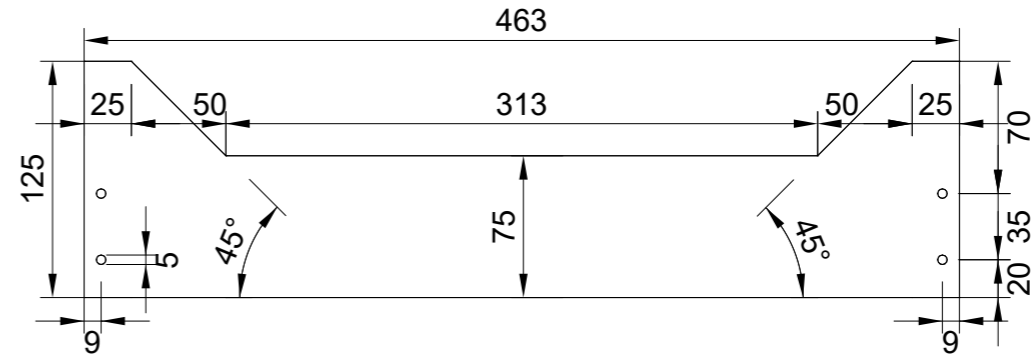

LH End (19mm solid pine):

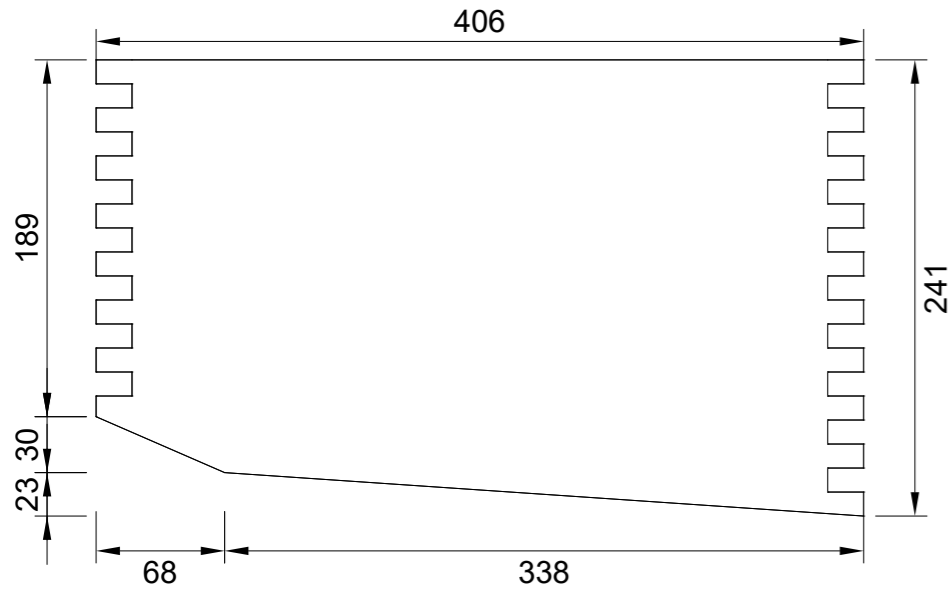

Top (19mm solid pine):

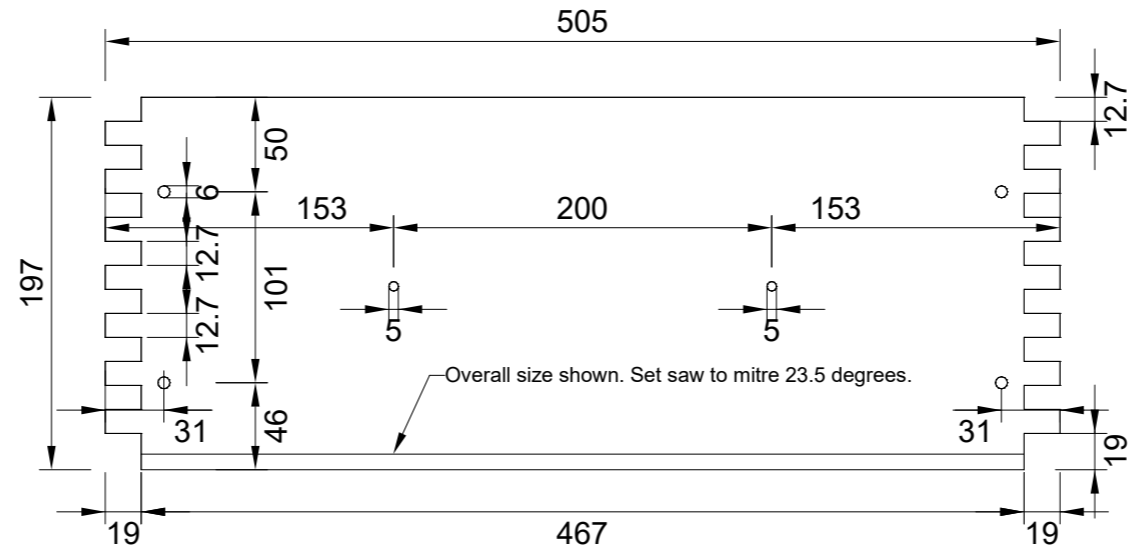

RH End (19mm solid pine):

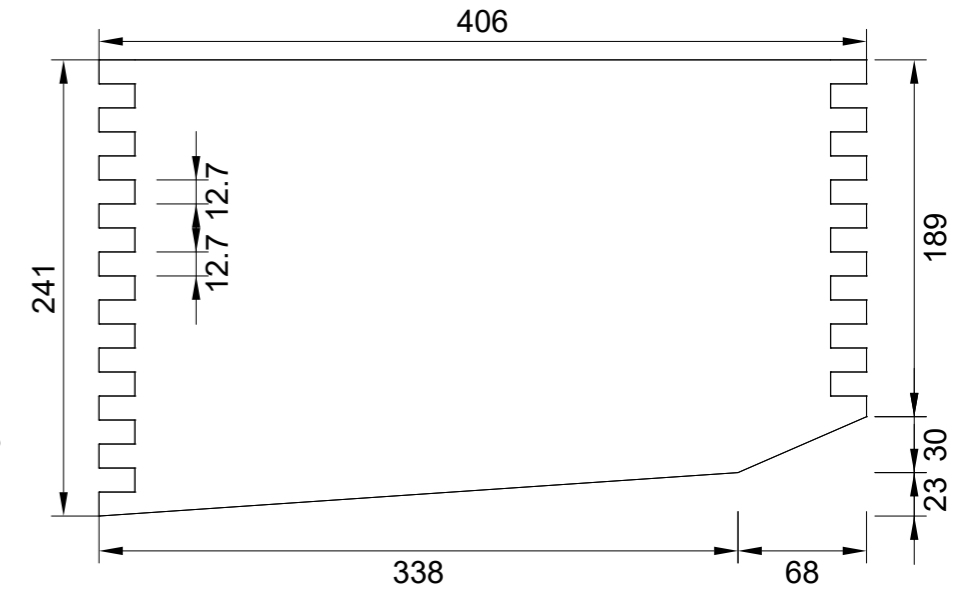

Baffle (9mm ply):

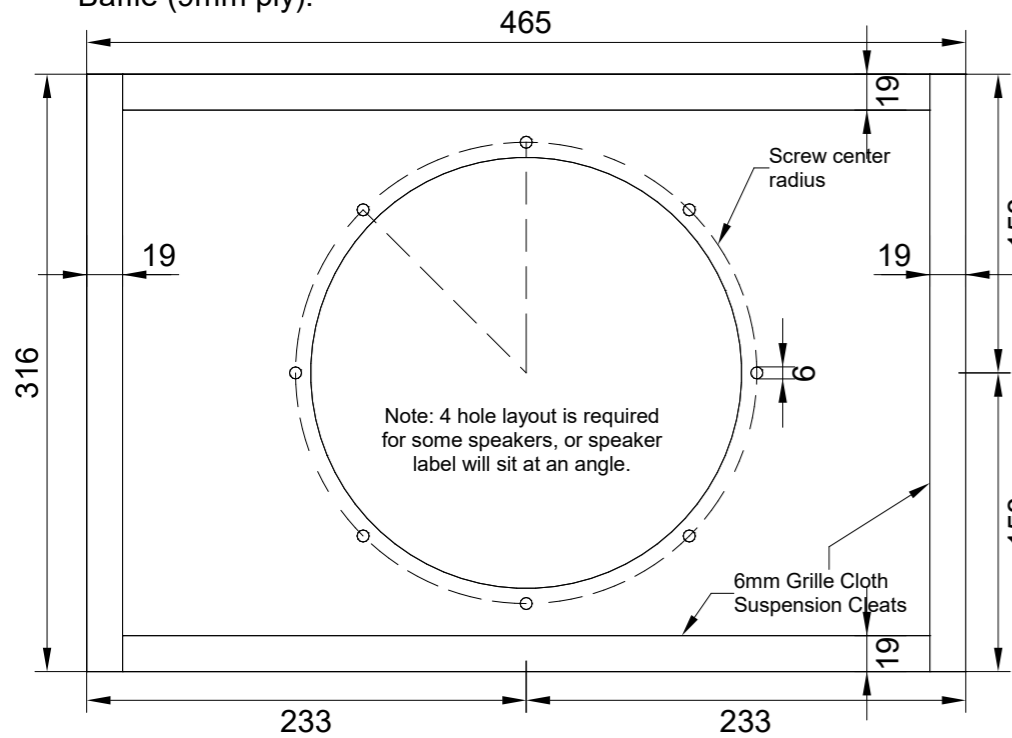

Base (19mm solid pine):

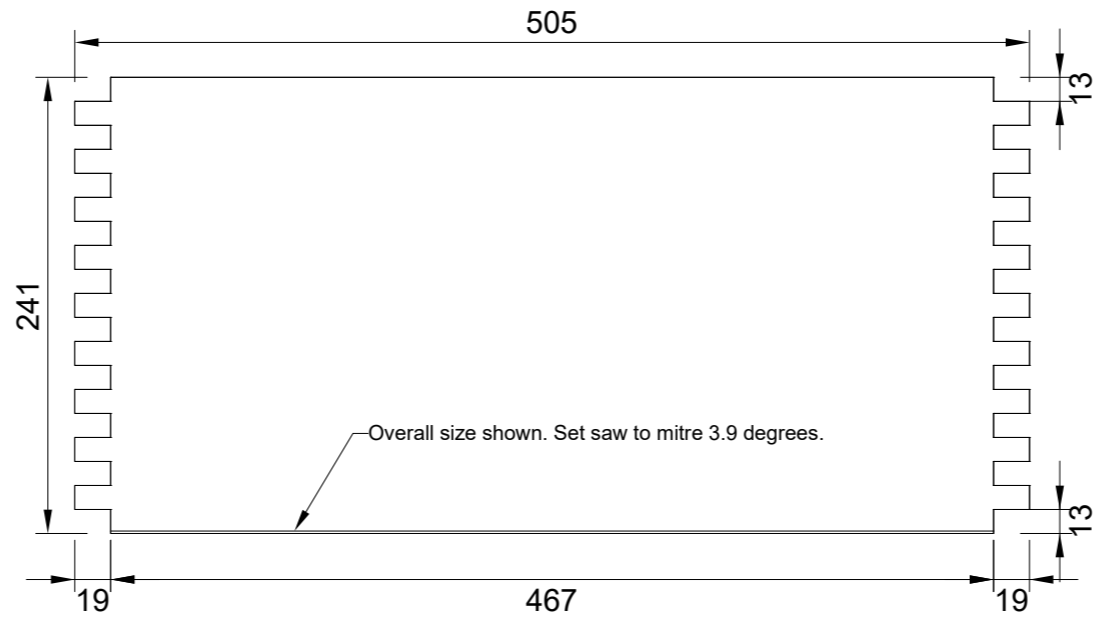

Baffle & Rear Panel Mounting Cleats (19mm solid pine):

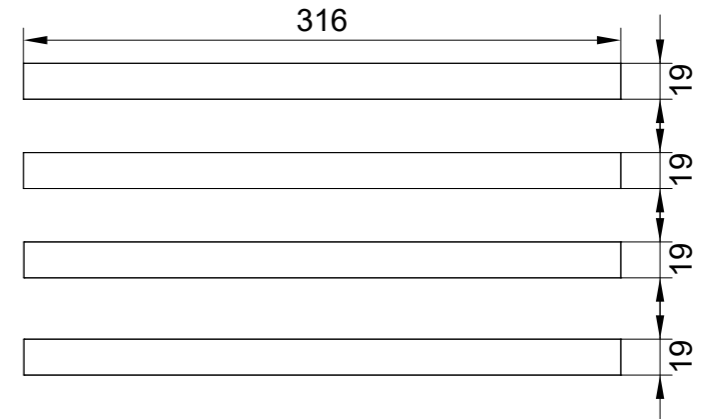

Notes:

- Drawings not to be reproduced without consent
- Check material thickness. Screw location and finger joint depth will have to be adjusted to suit.
- Allowance have been made for standard vinyl covering and approx 2mm thick grille cloth.
- Dimensions may need to be altered for other materials or timber finishing.
- It's suggested that all screws be fitted with suitable T-nuts or threaded inserts for longevity. Hole diameter may vary with hardware choice.
- Trial and error may be required with some hardware.
- Speaker cutout and mounting holes may vary with manufacturers. measure actual unit before drilling.



Project	BGG Cabinet Plans				
Title	PR Style Cabinet (10" Driver)				
Project No.	N/A	Sheet No:	2/2	Issue	A
Drawn By	BW	Scale	1:4@A3 (UNO)	Date	21/01/24